

Q345A, Q3451, Q3481, Q348A, Q348B, Q362A, Q373A, Q381A and Q3452 Intermittent Pilot Burner/Igniter-Sensors

PRODUCT DATA

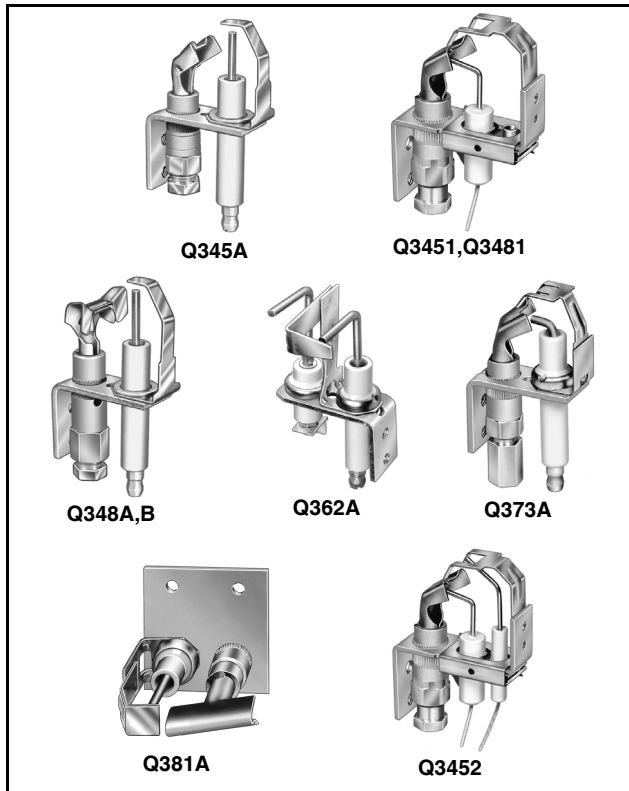

FEATURES

- Q345A, Q348A, Q348B and Q373A Intermittent Pilot Burner/Igniter-Sensors are compatible with all Honeywell intermittent ignition control modules.
- Q3451 and Q3481 Single-rod Pilot Burner/Igniter Sensors have an integral cable and bent rod that sparks to hood.
- Q362A Intermittent Pilot Burner/Igniter-Sensor is used with S86, S8610, S90, and S860 nonlockout and 90-second lockout modules.
- Q381A Intermittent Pilot Burner/Igniter-Sensor is used with S86 nonlockout and 90-second lockout modules.
- Q3452 Two-rod Pilot Burner/Igniter Sensor is used with S8600A,B,C; S8610A,B,C,U; S8620C; S8600J,K; and S8670J,K Two-rod Ignition Modules.
- Q362A is for low BTU applications.
- Q381A is for horizontal mounting only.
- 15,000V open circuit spark ignition.
- Natural and LP gas orifices available.
- Variety of target styles available.
- Variety of mounting brackets available.

APPLICATION

The Intermittent Pilot Burner/Igniter-Sensors consist of low output conventional target type pilot burners and either a combination spark igniter and flame sensor or a separate spark igniter and flame sensor (two rod) mounted in place of the thermocouple.

Contents

Application	1
Features	1
Specifications	2
Ordering Information	2
Installation	14
Startup and Checkout	16
Operation	17
Service	17



SPECIFICATIONS

IMPORTANT

The specifications given in this publication do not include normal manufacturing tolerances. Therefore, this unit might not exactly match the listed specifications. Also, this product is tested and calibrated under closely controlled conditions, and some minor differences in performance can be expected when those conditions are changed.

TRADELINER® Models

TRADELINER models are selected and packaged for ease of handling, ease of stocking, and maximum replacement value. TRADELINE model specifications are the same as those of standard models, except as noted.

Additional Features:

Q345A, Q3451 and Q3481 Pilot Burner/Igniter-Sensors include a mounting bracket adapter for converting style B mounting brackets to style A mounting brackets.

Models: Refer to Table 1.

Target Styles and Flame Patterns: Refer to Fig. 12.

Mounting Brackets and Dimensions:

Refer to Fig. 1 through 10.

Style A Mounting Bracket Adapter Dimensions:

Refer to Fig. 11.

Type of Gas: Models available for Natural and LP gas.

ORDERING INFORMATION

When purchasing replacement and modernization products from your TRADELINE® wholesaler or distributor, refer to the TRADELINE® Catalog or price sheets for complete ordering number. If you have additional questions, need further information, or would like to comment on our products or services, please write or phone:

1. Your local Honeywell Environmental and Combustion Controls Sales Office (check white pages of your phone directory).
2. Honeywell Customer Care
1985 Douglas Drive North
Minneapolis, Minnesota 55422-4386
3. <http://customer.honeywell.com> or <http://customer.honeywell.ca>

International Sales and Service Offices in all principal cities of the world. Manufacturing in Belgium, Canada, China, Czech Republic, Germany, Hungary, Italy, Mexico, Netherlands, United Kingdom, and United States.

Table 1. Model Specifications.

Models	Type of Gas	Orifice Type	Target Style and Mounting Brackets	Accessories (Specify when ordering)
Q345A	Natural and LP	Insert	Refer to Fig. 1 and 2	Bleed tube clip compression fitting
Q3451	Natural and LP	Insert	Refer to Fig. 3	Bleed tube clip compression fitting
Q3481	Natural and LP	Insert	Refer to Fig. 4	Bleed tube clip compression fitting
Q373A	Natural and LP	Insert	Refer to Fig. 5	Bleed tube clip compression fitting
Q348A and Q348B	Natural and LP	Spud	Refer to Fig. 6 and 7	Bleed tube clip compression fitting
Q362A	Natural and LP	Insert	Refer to Fig. 8	Bleed tube clip compression fitting
Q381A	Natural and LP	Insert	Refer to Fig. 9	Bleed tube clip compression fitting
Q3452	Natural and LP	Insert	Refer to Fig. 10	N/A

Maximum Temperature Ratings:

Ignition Electrode Insulator: Most models: 1775 °F (968 °C);
 Q3452 only: 1250 °F (677 °C).
 Pilot Burner Target Tip: 1500 °F (816 °C).
 Insulator: 1250 °F (677 °C).
 Cable Temperature (for Q3451 model only): 484 °F (250 °C).
 Bracket: 1000 °F (538 °C).
 Orifice: 800 °F (427 °C).

Electrode/Flame Rod Material: Kanthal.

Spark Gap:

Q3451, Q3452: 0.080 in. to 0.140 in.
 Q3481: 0.090 to 0.140 in.
 All other models: 1/8 in. (3 mm)

Wiring Connection:

Most models: Single 1/4 in. (6 mm) diameter base stud for ignition cable;
 Q3452 only: 1/4 in. (6 mm) quick connect for igniter rod, .187 in. quick connect for sensor rod.

Ignition Cable (All except Q3451, Q3481 and Q3452):

Refer to Table 2.

Table 2. Recommended Ignition Cables.

Cable Type	Vrms Rating	Temperature Rating	
		°F	°C
UL Style 3217	10,000	302	150
UL Style 3257	10,000	484	250

Approvals:

Underwriters Laboratories Inc. Listed:
 File no. MH9928
 Guide no. MCUR2.
 CSA Certified: File no. 112395.

Accessories:

386449 Replacement 1/4 in. OD Compression Fitting.

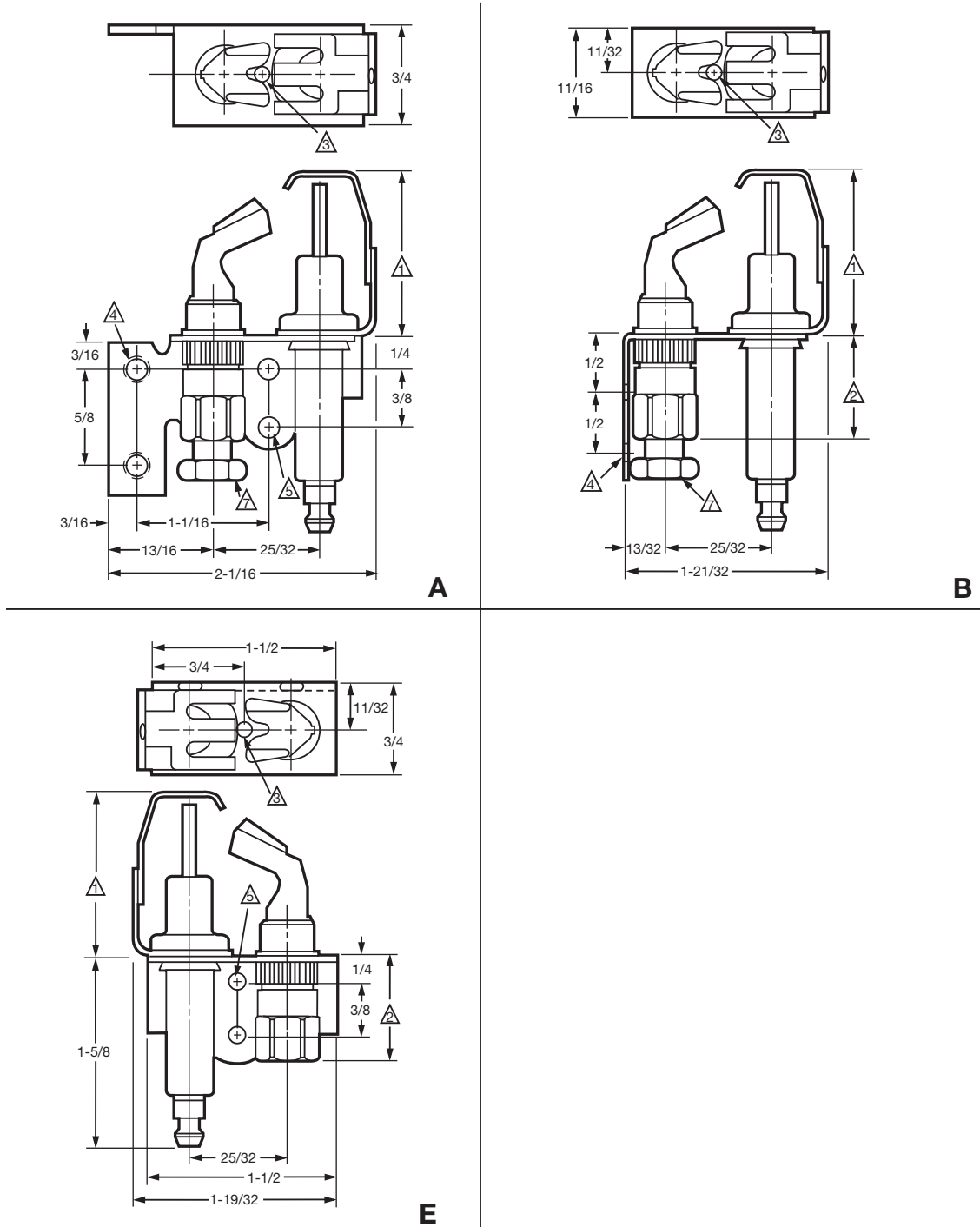

	IN.	MM	IN.	MM	IN.	MM	IN.	MM
△ 1-3/8 IN. STANDARD, 1-9/16 IN. RAISED.	1/32	0.8	5/16	7.9	19/32	15.1	7/8	22.2
△ 7/8 IN. STANDARD, 11/16 IN. RAISED.	1/16	1.6	11/32	8.7	5/8	15.9	29/32	23.0
△ HOLE FOR BLEED TUBE.	3/32	2.4	3/8	9.5	21/32	16.7	15/16	23.8
△ MOUNTING HOLE (2), TAPPED FOR 10-32 NC SCREW.	1/8	3.2	13/32	10.3	11/16	17.5	31/32	24.6
△ MOUNTING HOLE (2), 11/64 IN. DIA (4 MM) (CLEARS NO. 8 SCREW).	5/32	4.0	7/16	11.1	23/32	18.3	1	25.4
△ MOUNTING HOLE (2), 13/64 IN. DIA (5 MM) (CLEARS NO. 10 SCREW).	3/16	4.8	15/32	11.9	3/4	19.1	2	50.8
△ MOUNTING HOLE (2), 13/32 IN. DIA (5 MM) (CLEARS NO. 10 SCREW).	7/32	5.6	1/2	12.7	25/32	19.8		
△ 1/4 IN. COMPRESSION FITTING.	1/4	6.4	17/32	13.5	13/16	20.6		
	9/32	7.1	9/16	14.3	27/32	21.4		

M401C

Fig. 1. A, B, and E mounting bracket dimensions in in. (mm) for Q345A.

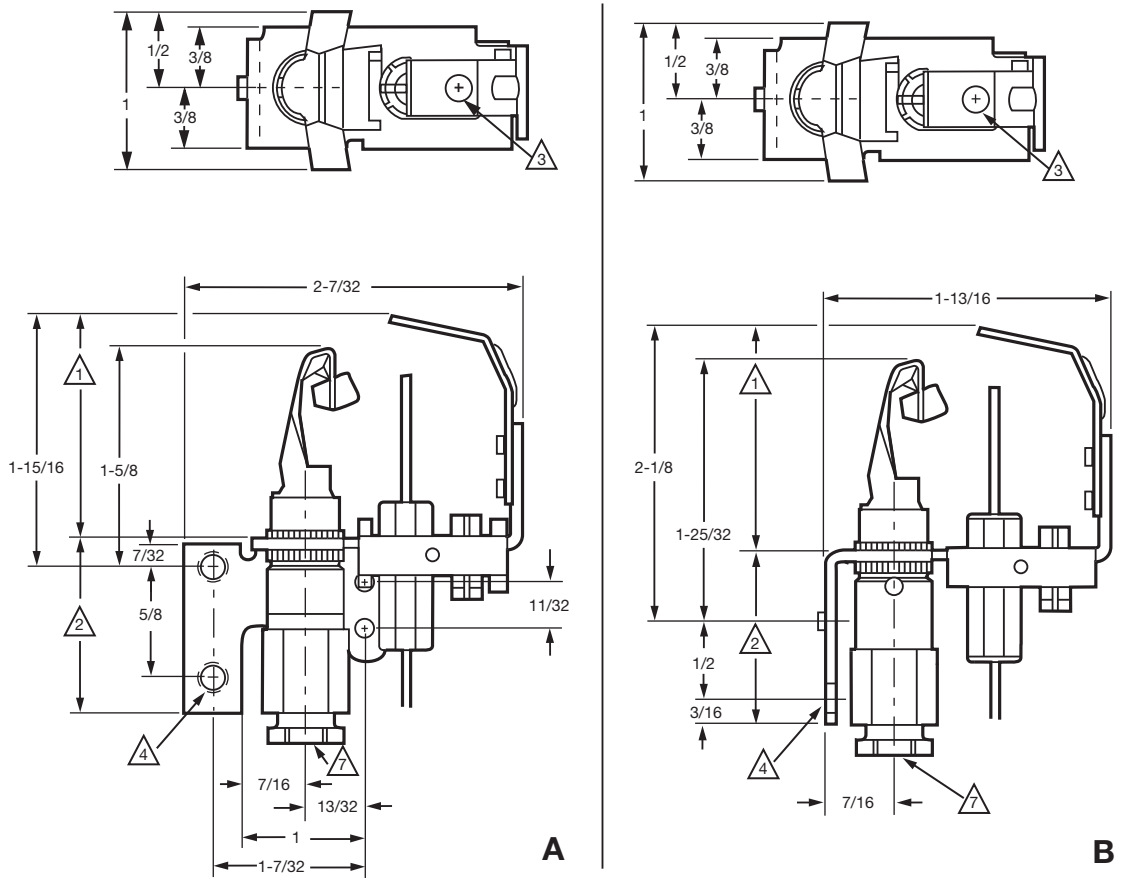

▲	1-3/8 IN. STANDARD, 1-9/16 IN. RAISED.	1/32	0.8	5/16	7.9	19/32	15.1	7/8	22.2
▲	7/8 IN. STANDARD, 11/16 IN. RAISED.	1/16	1.6	11/32	8.7	5/8	15.9	29/32	23.0
▲	HOLE FOR BLEED TUBE.	3/32	2.4	3/8	9.5	21/32	16.7	15/16	23.8
▲	MOUNTING HOLE (2), TAPPED FOR 10-32 UNF SCREW.	1/8	3.2	13/32	10.3	11/16	17.5	31/32	24.6
▲	MOUNTING HOLE (2), 11/64 IN. DIA (4 MM) (CLEARS NO. 8 SCREW).	5/32	4.0	7/16	11.1	23/32	18.3	1	25.4
▲	MOUNTING HOLE (2), 13/64 IN. DIA (5 MM) (CLEARS NO. 10 SCREW).	3/16	4.8	15/32	11.9	3/4	19.1	2	50.8
▲	MOUNTING HOLE (2), 13/64 IN. DIA (5 MM) (CLEARS NO. 10 SCREW).	7/32	5.6	1/2	12.7	25/32	19.8		
▲	1/4 IN. COMPRESSION FITTING.	1/4	6.4	17/32	13.5	13/16	20.6		
▲		9/32	7.1	9/16	14.3	27/32	21.4		

M4900B

Fig. 4. A and B mounting bracket dimensions in in. (mm) for Q3481.

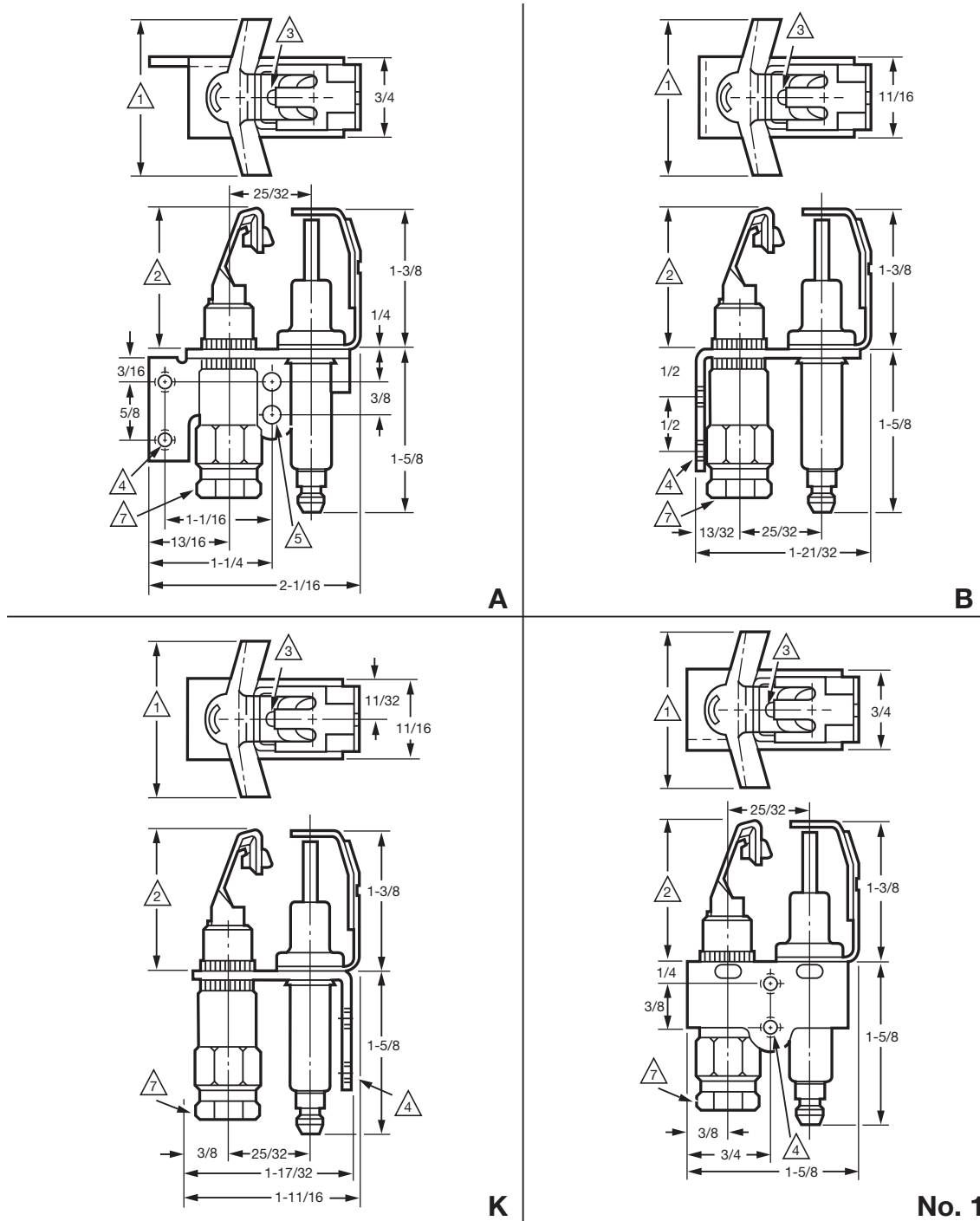

△1	SPECIFY WINGSPAN 1, 1-1/2, 2, OR 2-3/4 IN.	IN.	MM	IN.	MM	IN.	MM	IN.	MM
△2	1-1/4 TO 1-3/4 IN. DEPENDING ON WINGSPAN DIMENSION.	1/32	0.8	5/16	7.9	19/32	15.1	7/8	22.2
△3	HOLE FOR BLEED TUBE.	1/16	1.6	11/32	8.7	5/8	15.9	29/32	23.0
△4	MOUNTING HOLE (2), TAPPED FOR 10-32 NC SCREW.	3/32	2.4	3/8	9.5	21/32	16.7	15/16	23.8
△5	MOUNTING HOLE (2), 11/64 IN. DIA (4 MM) (CLEARS NO. 8 SCREW).	1/8	3.2	13/32	10.3	11/16	17.5	31/32	24.6
△6	MOUNTING HOLE (2), 13/64 IN. DIA (5 MM) (CLEARS NO. 10 SCREW).	5/32	4.0	7/16	11.1	23/32	18.3	1	25.4
△7	1/4 IN. COMPRESSION FITTING.	7/32	5.6	1/2	12.7	25/32	19.8	2	50.8
		1/4	6.4	17/32	13.5	13/16	20.6		
		9/32	7.1	9/16	14.3	27/32	21.4		

M403B

Fig. 6. A, B, K and No. 1 mounting bracket dimensions in in. (mm) for Q348A,B.

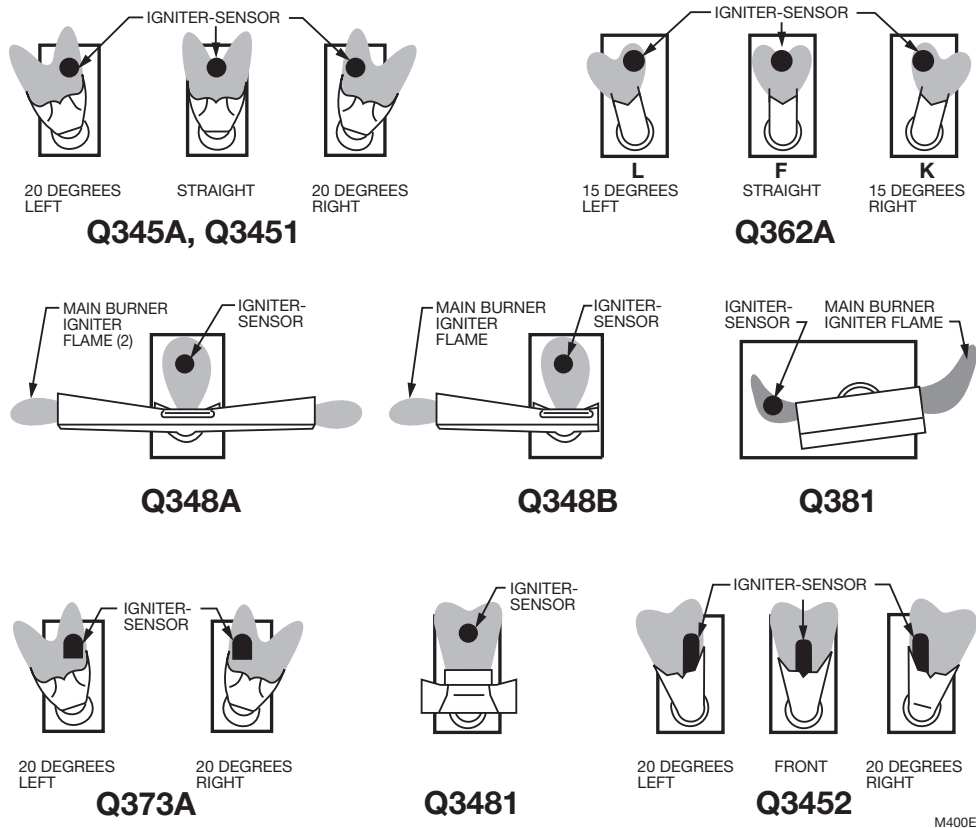

Fig. 12. Pilot burner/igniter-sensor target styles and flame patterns.

INSTALLATION

When Installing this Product...

1. Read these instructions carefully. Failure to follow the instructions can damage the product or cause a hazardous condition.
2. Check the ratings given in the instructions and on the product to make sure the product is suitable for your application.
3. Installer must be a trained, experienced service technician.
4. After installation is complete, check out product operation as provided in these instructions.



WARNING

FIRE OR EXPLOSION HAZARD. CAN CAUSE PROPERTY DAMAGE, SEVERE INJURY, OR DEATH.

Follow these warnings exactly:

1. Disconnect power supply before wiring to prevent electrical shock or equipment damage.
2. To avoid dangerous accumulation of fuel gas, turn off gas supply at appliance service valve before starting installation and perform Gas Leak Test after completion of installation.
3. Do not bend pilot tubing at the gas control or pilot burner after compression nut has been tightened. Gas leakage at the connection can result.

Follow the appliance manufacturer instructions, if available; otherwise, use the instructions provided.

Location

1. Position the pilot burner/igniter-sensor for easy access and observation. In replacement applications, replace the pilot burner/igniter-sensor with an identical unit and position the new pilot burner/igniter-sensor in the same location and orientation as the original one.
2. Mount the pilot burner/igniter-sensor on the main burner. Mounting surfaces other than the main burner can shift, bend, or warp as the furnace expands and contracts during operation. See Fig. 13.

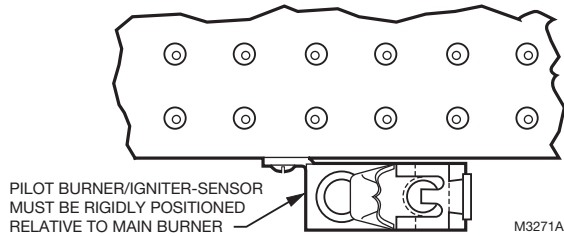

Fig. 13. Mount pilot burner/igniter-sensor on main burner.

3. Mount the pilot burner/igniter-sensor so that the pilot flame remains properly positioned with respect to the main burner flame. See Fig. 14.

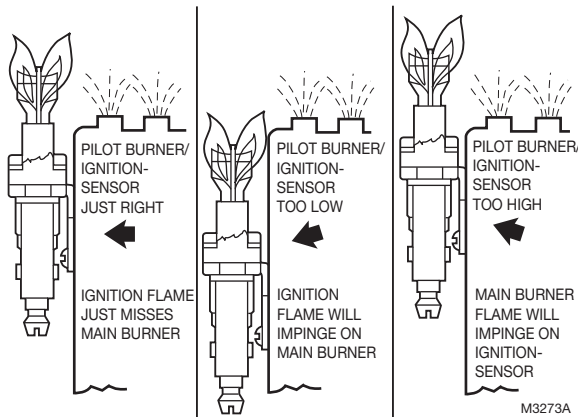

Fig. 14. Location of pilot burner/igniter-sensor.

4. Supply the pilot flame with ample air that is free of combustion products.
5. Do not impinge the pilot flame on adjacent parts. Do not impinge the main burner flame on the pilot burner/igniter-sensor.
6. Do not expose the pilot flame to falling scale that could impair the main burner ignition.
7. Do not expose the pilot burner/igniter-sensor to the main burner rollout during igniting or extinguishing.
8. Do not expose the pilot flame to drafts that push or pull the pilot flame away from the igniter-sensor.

NOTE: The Q381 Pilot Burner/Igniter-Sensor is only for horizontal mounting. Mounting bracket must remain vertical.

Connect Pilot Gas Tubing

1. Cut tubing to desired length and bend as necessary for routing to pilot burner/igniter-sensor. Do not make sharp bends or deform tubing. Do not bend tubing at control after compression nut is tightened because this can result in gas leakage at the connection.
2. Square off and remove the burrs from the end of the tubing.
3. Push tubing into the compression nut clearance hole until the tubing bottoms.

NOTE: When replacing a control, cut off the old compression fitting and replace with the new compression fitting provided with the new pilot burner. Never use the old compression fitting because it might not provide a gas-tight seal. See Fig. 15.

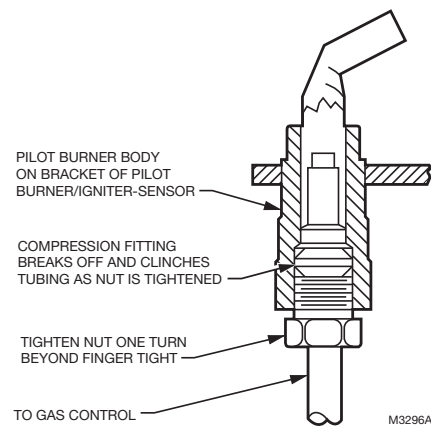

Fig. 15. Always use new compression fitting.

4. While holding the tubing all the way in, engage threads and turn until finger tight.
5. Using a wrench, turn the compression nut one turn beyond finger tight. Do not overtighten.
6. Connect the other end of the tubing to the gas control according to the gas control manufacturer instructions.

Connect Igniter Sensor Ground Wire

The igniter-sensor must be mounted on the burner. Connect the ignition module ground wire to one of the igniter-sensor mounting screws to complete the system grounding.

Connect ground wire as follows:

1. Use 221 °F (105 °C) minimum thermoplastic-insulated wire for the ground leadwire (asbestos insulation is not acceptable).
2. A male 1/4 in. (6.4 mm) quick-connect terminal is provided on the Honeywell ignition module. Fasten the female quick-connect to the wire end at the control module.
3. Strip the other end and fasten under the pilot burner/igniter-sensor mounting screw.
4. If necessary, use a shield to protect the ground wire from the main burner radiant heat.
5. The pilot burner/igniter-sensor serves as the grounding area for the flame signal. Run a lead from the pilot burner to the common ground selected.

Connect the ignition cable (except Q3451, Q3481 and Q3452) as follows:

1. The high tension ignition cable must conform to applicable local or national standards.
2. Connect one end of the ignition cable to the stud terminal on the igniter-sensor and the other end to the stud terminal on the ignition module using 1/4 in. (6.4 mm) diameter snap-spring or cage-clips on the cable ends.
3. Use ceramic or plastic standoff insulators as necessary to prevent the ignition cable from contacting metal surfaces.

Connect the Q3451 and Q3481 integral cables as follows:

Connect the Q3451 and Q3481 integral cables to the spark terminal of the S8600 ignition module.

Connect the Q3452 spark igniter rod and flame sensing rod cables as follows:

1. Connect the leadwire (with black insulated 1/4 in. quick connect) of the spark igniter rod to the spark terminal of the S8600 Ignition Module. Do not allow the leadwire to touch grounded metal surfaces, because this will reduce the voltage available at the spark gap.
2. Connect the leadwire of the flame sensing rod to the sense terminal of the S8600 Ignition Module.

Install Bleed Gas Tube (Optional)

1. Route the bleed tube from the bleed tap on the gas control to the pilot burner/igniter-sensor.
2. Push the clip into place. See Fig. 16.

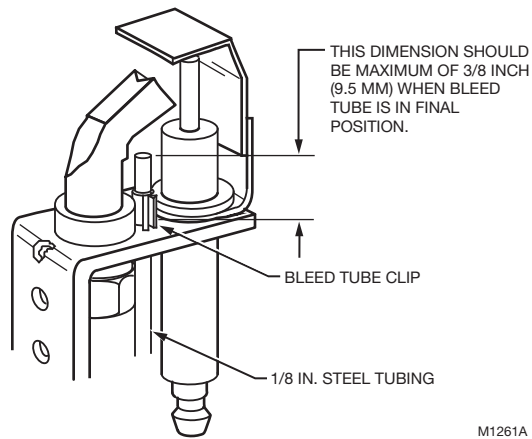

Fig. 16. Install bleed gas tube.

3. Insert the bleed gas tube until 3/8 in. (10 mm) of tubing is above the pilot burner/igniter-sensor bracket. The tip of the bleed gas tube must not extend into the pilot flame.

Install Style A Mounting Bracket Adapter (Refer to Fig. 11.)

To convert the mounting bracket from style B to style A, install the A mounting bracket adapter on the pilot burner/igniter-sensor mounting bracket. Then install the pilot burner/igniter-sensor on the main burner.

STARTUP AND CHECKOUT

Follow the startup and checkout procedures for the gas control and the ignition module. Refer to the appliance manufacturer instructions because the application and controls used can differ. The following steps must be performed during all checkout procedures.

Perform Gas Leak Test



WARNING

FIRE OR EXPLOSION HAZARD. CAN CAUSE PROPERTY DAMAGE, SEVERE INJURY, OR DEATH.

Check for gas leaks with soap and water solution any time work is done on a gas system.

Gas Leak Test

1. Be sure gas supply is turned on at the appliance service valve.
2. Paint the pipe connections upstream of the pilot burner with a rich soap and water solution. Bubbles indicate a gas leak.
3. If a leak is detected, tighten the pipe connections.
4. Set the thermostat to call for heat to light the main burner.
5. With the main burner in operation, paint the pipe joints (including adapters) and gas control inlet and outlet with a rich soap and water solution.
6. If another leak is detected, tighten the adapter screws, joints, and pipe connections.
7. Replace the part if the leak cannot be stopped.

Adjust Pilot Flame

The pilot flame should envelop 3/8 to 1/2 in. (10 to 13 mm) of the igniter-sensor tip (for all except Q3452, Q3481). Q3452 and Q3481 require 1/4 to 1/2 in. (6 to 13 mm). See Fig. 17. To adjust the pilot flame:

1. Turn off the system by setting the thermostat below the temperature to call for heat.
2. Disconnect the lead to the MV terminal on the gas control.
3. Light the pilot by setting the thermostat to call for heat.
4. Remove the pilot adjustment cover screw from the gas control.
5. Turn the inner pilot adjustment screw clockwise to decrease or counterclockwise to increase the pilot flame.
6. Replace the pilot adjustment cover screw and tighten firmly after adjustment is complete to ensure proper operation.

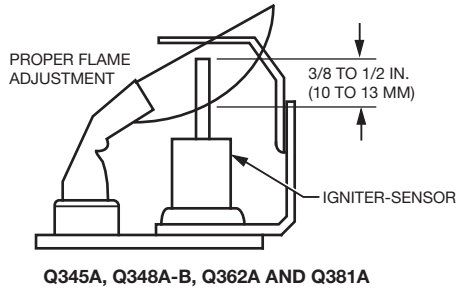

Q345A, Q348A-B, Q362A AND Q381A

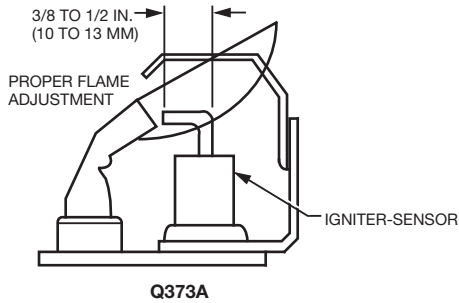

Q373A

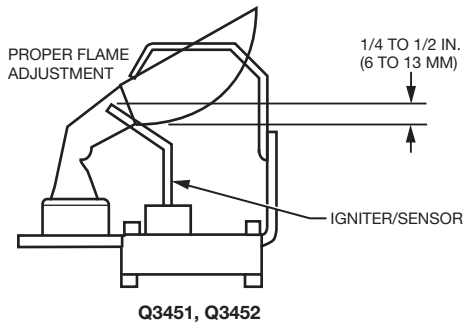

Q3451, Q3452

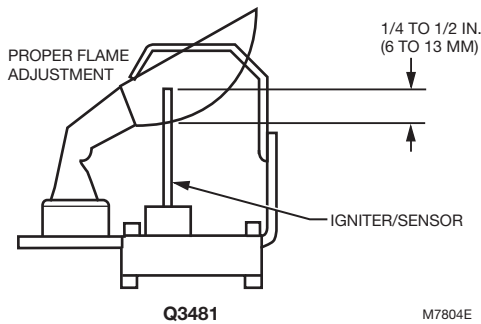

Q3481

M7804E

Fig. 17. Igniter-sensor tip must be in pilot flame.

OPERATION

The Q345, Q3451, Q3481, Q348, Q362, Q373, Q381, and Q3452 are conventional style pilot burners fitted with igniter/sensing rod(s) and a ground strap to ignite and sense the presence of pilot flame. See Fig. 18.

When the ignition module is energized, voltage is applied to the igniter-sensor and sparking occurs between the insulated rod and the ground strap; however, for Q373 and Q3452, sparking occurs between the spark rod and the pilot target. When the spark ignites the pilot gas, gas molecules between the flame

rod and the ground strap become ionized and are able to conduct an electrical current. Current through the flame results in a pulsating direct current. The pilot flame monitoring circuit in the ignition module responds to the pulsating direct current and stops current to the spark igniter. Current for flame sensing continues until the call for heat ends, the pilot flame is extinguished, or power is interrupted.

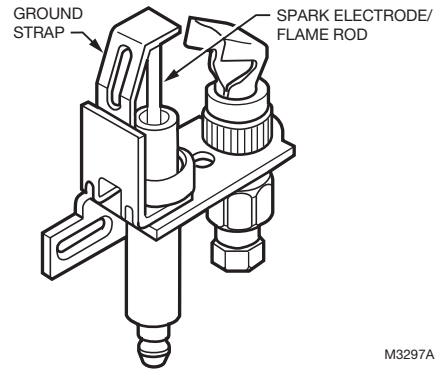

M3297A

Fig. 18. Pilot burner/igniter-sensor (Q345 shown).

SERVICE



WARNING

FIRE OR EXPLOSION HAZARD. CAN CAUSE PROPERTY DAMAGE, SEVERE INJURY, OR DEATH.
Perform Gas Leak Test any time work is done to the system.

Pilot Outage

1. If the pilot flame goes out during ignition, but is properly adjusted, recheck the Location instructions.
2. Refer to the ignition module instructions to check the wiring between the igniter-sensor and the ignition module or between the gas control and the ignition module.
3. If all Location instructions are followed, but the pilot continues to go out, construct a shield to protect the pilot flame from the main burner ignition, extinction and drafts. See Fig. 19.

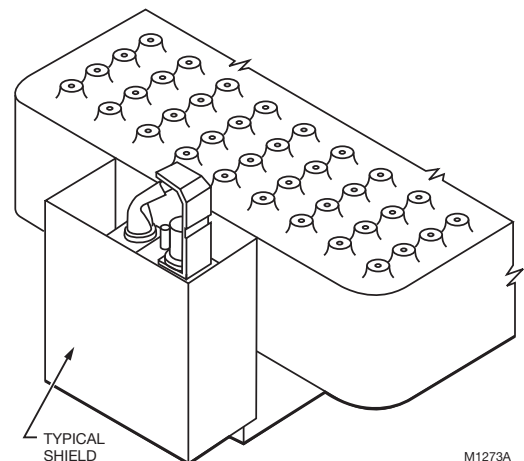











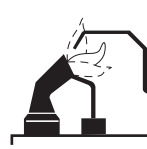
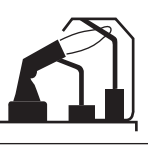









Fig. 19. Proper shielding of pilot flame.

4. Check pilot and main burner lightoff.
 - a. Set the thermostat to call for heat.
 - b. Watch the pilot burner during the ignition sequence. To determine if:
 - (1) Ignition spark continues after the pilot is lit.
 - (2) Pilot lights and the spark stops, but the main burner does not light.
 - (3) S8600B, H; S8660H only: Pilot lights, the spark stops and the main burner lights, but the system locks out.
 - c. If pilot burner is functioning correctly, ensure adequate flame current as follows:

- (1) Turn off furnace at circuit breaker or fuse box.
- (2) Clean the flame rod with emery cloth.
- (3) Make sure electrical connections are clean and tight. Replace damaged wire with moisture-resistant No. 18 wire rated for continuous duty up to 221 °F (105 °C).
- (4) Check for cracked ceramic insulator, which can cause a short to ground, and replace the igniter-sensor if necessary.
- (5) At the gas control, disconnect the main valve wire from the TH or MV terminal.
- (6) Turn on power and set the thermostat to call for heat. The pilot should light but the main burner will remain off because the main valve actuator is disconnected.
- (7) Check the pilot flame. Make sure it is blue, steady and envelops 3/8 to 1/2 in. (10 to 13 mm) of the flame rod (except for Q3452 and Q3481 that envelop 1/4 to 1/2 in. [6 to 13 mm]). See Fig. 20 for possible flame problems and causes.

APPEARANCE	APPEARANCE	APPEARANCE	APPEARANCE	CAUSE
SMALL BLUE FLAME 	SMALL BLUE FLAME 	SMALL BLUE FLAME 	SMALL BLUE FLAME 	CHECK FOR LACK OF GAS FROM: <ul style="list-style-type: none"> • CLOGGED ORIFICE FILTER • CLOGGED PILOT FILTER • LOW GAS SUPPLY PRESSURE • PILOT ADJUSTMENT AT MINIMUM
LAZY YELLOW FLAME 	LAZY YELLOW FLAME 	LAZY YELLOW FLAME 	LAZY YELLOW FLAME 	CHECK FOR LACK OF AIR FROM: <ul style="list-style-type: none"> • DIRTY ORIFICE • DIRTY LINT SCREEN, IF USED • DIRTY PRIMARY AIR OPENING, IF THERE IS ONE • PILOT ADJUSTMENT AT MINIMUM
WAVING BLUE FLAME 	WAVING BLUE FLAME 	WAVING BLUE FLAME 	WAVING BLUE FLAME 	CHECK FOR: <ul style="list-style-type: none"> • EXCESSIVE DRAFT AT PILOT LOCATION • RECIRCULATING PRODUCTS OF COMBUSTION
NOISY LIFTING BLOWING FLAME 	NOISY LIFTING BLOWING FLAME 	NOISY LIFTING BLOWING FLAME 	NOISY LIFTING BLOWING FLAME 	CHECK FOR: <ul style="list-style-type: none"> • HIGH GAS PRESSURE
HARD SHARP FLAME 	HARD SHARP FLAME 	HARD SHARP FLAME 	HARD SHARP FLAME 	THIS FLAME IS CHARACTERISTIC OF MANUFACTURED GAS CHECK FOR: <ul style="list-style-type: none"> • HIGH GAS PRESSURE • ORIFICE TOO SMALL

M4895A

Fig. 20. Examples of unsatisfactory pilot flames.

- (8) If necessary, adjust the pilot flame by turning the pilot adjustment screw on the gas control clockwise to decrease or counterclockwise to increase

pilot flame. Following the adjustment, always replace pilot adjustment cover screw and firmly tighten to ensure proper gas control operation.

- (9) Set thermostat below room temperature to end the call for heat.

- d. Recheck ignition sequence as follows:

- (1) Reconnect the main valve wire.
- (2) Set thermostat to call for heat.
- (3) Watch the ignition sequence at the burner.
- (4) If spark still does not stop after pilot lights, replace the ignition module.
- (5) If main burner does not light or if main burner lights but system locks out, check ignition module, ground wire, and gas control as described in the ignition module instructions.

Check Ignition Cable

(all except Q3451, Q3481 and Q3452)

1. Be sure that the ignition cable is not in contact with metal surfaces.
2. Be sure that the ignition cable is not more than 3 ft (1 mm) long.
3. Be sure that the connections to the ignition module stud terminal and the igniter-sensor are clean and tight.
4. Check the electrical continuity of the ignition cable.

Check Ignition and Sensor Leadwires

(Q3451, Q3481 and Q3452 only)

1. Ensure that the spark igniter rod leadwire is not in contact with metal surfaces.
2. Ensure that the connections to the ignition module and the igniter and sensor are clean and tight.

Check Spark Gap

On all models, (except Q3451, Q3481 and Q3452), the spark gap is 1/8 in. (3 mm).

For Q3451 and Q3452; the spark gap is between 0.080 in. and 0.140 in.

For Q3481; the spark gap is between 0.090 in. and 0.140 in.

If the gap is outside of these specifications, use a needlenose pliers to bend the rod to bring the gap within the specification.

Check Grounding

1. When frequent shutdowns are reported, check the ground wire instructions in the Installation section. When the ground is poor or erratic, safety shutdown occurs.
2. If the leadwire is damaged or deteriorated, use No. 14 to 18 gauge, moisture-resistant, thermoplastic, insulated wire with 221 °F (105 °C) minimum rating as a replacement.
3. Excessive temperature at the ceramic flame rod insulator allows electrical leakage to ground.
 - a. If bracket is bent, bend it back to correct position.
 - b. If insulator is cracked, replace the pilot burner/igniter-sensor.

Safety Lockout

Refer to appliance manufacturer instructions to test for proper safety lockout times.